

Extended BMW Exx CIC CAMERA Emulator

Software Version 1.2x.0x

User and installation manual

Revision 2 11/2015



READ THIS INSTALLTION MANUAL CAREFULLY BEFORE YOU START!

It is strongly recommended to perform this installation by using services of installer with appropriate knowledge and experience in automotive electronics. Installation should be performed with disconnected battery due to safety reasons.

Table of contents

Description	3
Connection	6
Menu	8
Setting the parking lines	9
Appendix A [HeadUnit video input variants]	10
Appendix B [Typical connection]	11

Designation

This module is designed for installation on BMW Exx cars with head unit HU CIC for emulation of TRSVC control unit. In case if the car is not equipped with PDC module emulates functioning of PDC. The module also adds markings to rear view camera image of the path of the vehicle depending on the steering angle (hereinafter - **the parking lines**).

Description

Module has 8 switches for switching on and off additional functions. Switches designation are shown in the Table 1. You can find recommended switches configuration are shown in the Table 2.

Table 1 Switches designation

State	SW0	SW1	SW2	SW3	SW4	SW5	SW6	SW7
ON	Video in motion on	Navi is activated	Old parktronic protocol conversion is on (E90**)	Parktronic emulation for new model is on (E70, E84, E90)	Parktronic emulation for old model is on (E60)	RVC Emulation is on (E70, E71, E84, E90**)	Special control mode for RVC emulation is on (E60)	Joystick capture option enable
OFF	Video in motion off	Navi is not activated	Old parktronic protocol conversion is off	Parktronic emulation for new model is off	Parktronic emulation for old model is off	RVC emulation is off	Special control mode for RVC emulation is off	Joystick capture option disable

**** - for CIC E90, coded to work with rearview camera.**

Note: For correct operation of the module with the head unit should be set to one of three switches SW2, SW3 and SW4, and one of the two switches SW5 or SW6.

Table 2 Recommended switches configurations

Initial -> final configuration	SW0	SW1	SW2	SW3	SW4	SW5	SW6	SW7
E70 -> E70 + PDC	X	X	-	+	-	+	-	X
E70 -> E70 + PDC + TRSVC	X	X	-	+	-	+	-	X
E70 + PDC -> E70 + PDC + TRSVC	X	X	-	+	-	+	-	X
E90 -> E90 + PDC	X	X	-	-	+	+	-	X
E90 -> E90 + PDC + TRSVC	X	X	-	+	-	+	-	X
E90 + PDC -> E90 + PDC + TRSVC	X	X	+	-	-	+	-	X
E60 -> E60 + PDC	X	X	-	-	+	+	-	X
E60 -> E60 + PDC + TRSVC	X	X	-	-	+	-	+	X
E60 + PDC -> E60 + PDC + TRSVC	X	X	-	-	+	-	+	X

“X” – can be any, **“-”** – opened, **“+”** – closed.

Module has also output “ACC Out” for controlling an external relay. Output is activated when key switched to the ON position.

In case user activates special option of controlling RVC for E60 (these cars has no RVC option from the factory) HeadUnit must be coded with NightVision (NiVi) option. Sequence of modes switching in E60 is shown in Table 3.

Table 3 Sequence of modes switching in special control mode

	Event	PDC installed	PDC is not installed
1	Rear gear	Turn on video from RVC, sound from PDC	Turn on of the image from RVC and emulation of PDC
2	Change to the other gear	Turn off video from RVC, image from PDC or board computer (BC)	Turn off of the video from RVC, image from BC
3	Continuous pressing of the button on the steering wheel	PDC state is not changed. Every press of the button changes image sources. (PDC or BC) -> (RVC) -> (PDC or BC) -> etc	PDC state is not changed. Every pressing of the button changes image sources. (PDC or BC) -> (RCV) -> (PDC or BC) -> etc
4	Pressing of the PDC button on the IHKA	Turn off video from RVC, image from PDC or board computer (BC)	Every pressing changes image sources 1 PDC 2 RVC, PDC only sound 3 BC

Connection

Module has to be connected into CAN bus of the car directly at the connector 3 of the head unit. If rear camera is present module connected to the video gap (between the camera and the head unit).

Typical connection is shown on Fig 4. X and Y pins numbers depends on car complication. Possible combinations you can find on the Table 4.

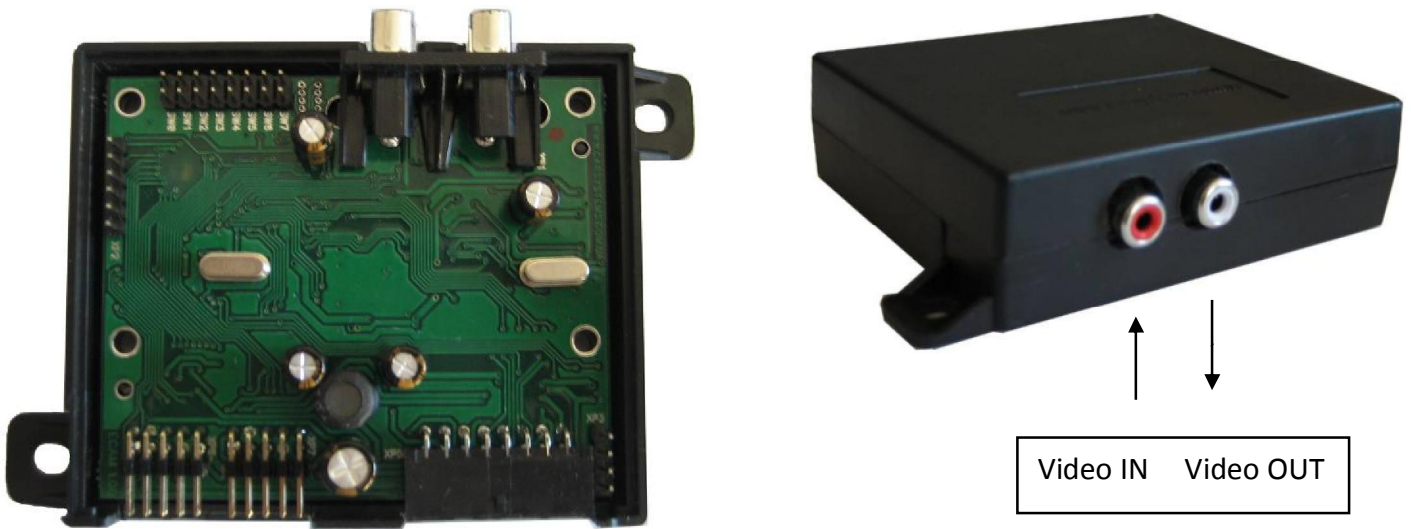
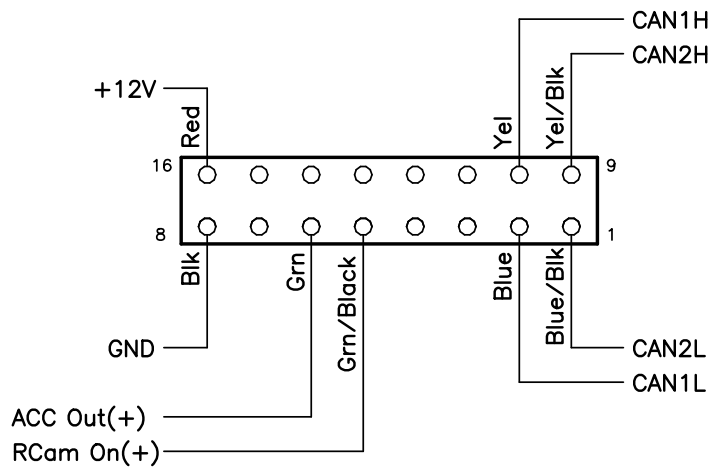

Fig 1 Design and pinout of the module





For correct functioning HeadUnit and PDC (if present) must be coded with the following options (in the Table 4).

Table 4 Required options for the correct operation

	Option for PDC	Option for CIC
E70, E71, E74	508	3AG
E90	508	
E60	508	

Menu

Setup menu is caused by prolonged retention button (default - «MENU») - jumper SW7 must be installed.

Navigation in menu is done by rotating the wheel of joystick. Rotation to the left side - menu cursor up to the right - cursor down, pressing the joystick (enter to sub-menus) and «BACK» key (return from sub-menu).

MAIN MENU. Contains submenus: Parking lines, Obstacles highlight, System settings, Engineer's menu.

Paragraph Parking lines. Contains a checkboxes to enable/disable parking lines, submenu Vehicle parameters, Camera parameters, Predefined vehicles, Load default settings.

Paragraph Vehicle parameters - contains parameters of the vehicle - the length, width, tire width, the distance between the tires of a vehicle border point, the thickness of the boundary lines on the display.

Paragraph Camera parameters - contains camera parameters - pitch, height, rotation, focal length, and the offset from the center shift relative to the edge of the car.

Paragraph Predefined vehicles (in this version is inactive).

Paragraph Load default settings - to load the default settings.

Paragraph Obstacles highlight (in this version is inactive).

Paragraph System settings – contains a sub-menu Switches configuration, Menu call key select, System info, Load default settings.

Paragraph Switches configuration - displays the current configuration jumpers. Read-only.

Paragraph Menu call key select - used to select the menu button .

Paragraph System info - displays the version of hardware, software and the firmware loader.

Paragraph Load default settings (in this version is inactive).

Paragraph Engineer's menu - contains information about the density of traffic on the CAN bus and VIN head unit.

Setting parking lines

To correctly display the parking lines must be configured for the car.

Use MAIN MENU-> Parking lines-> Camera parameters to set the camera position - its pan, tilt , and height. Use MAIN MENU-> Parking lines-> Vehicle parameters to configure the car parameters.

Appendix A

Table 5 Possible variants of rear camera connection to the HeadUnit CIC

	VideoIn(X)	VideoGround(Y)
variant 1	18	28
variant 2	19	26
variant 3	21	24
E90, E60	18	28

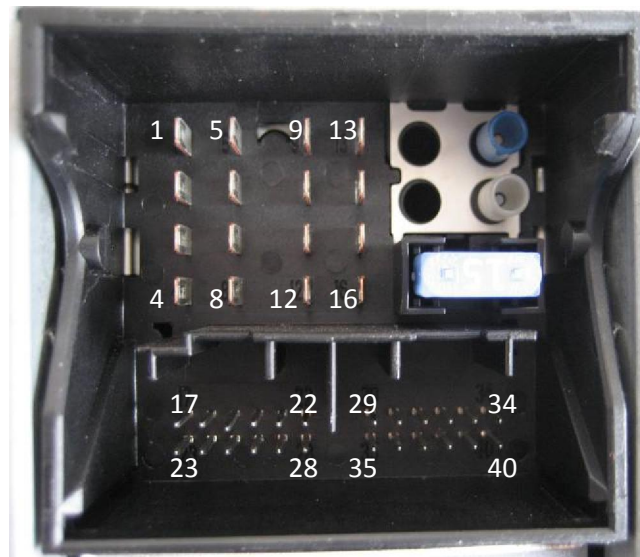

Fig 3 Pinout of the connecting plug for head unit CIC

Appendix B

